

Lesson 6: General Prisms and Cylinders and Their Cross-Sections

Classwork

Opening Exercise

Sketch a right rectangular prism.

RIGHT RECTANGULAR PRISM: Let E and E' be two parallel planes. Let B be a rectangular region¹ in the plane E . At each point P of B , consider $\overline{PP'}$ perpendicular to E , joining P to a point P' of the plane E' . The union of all these segments is called a *right rectangular prism*.

GENERAL CYLINDER: (See Figure 1.) Let E and E' be two parallel planes, let B be a region² in the plane E , and let L be a line that intersects E and E' but not B . At each point P of B , consider $\overline{PP'}$ parallel to L , joining P to a point P' of the plane E' . The union of all these segments is called a *general cylinder with base B* .

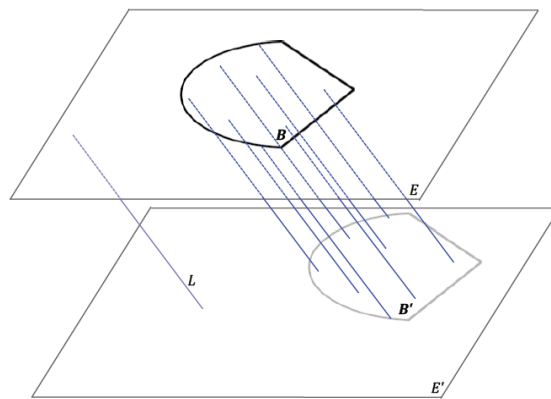

Figure 1

¹(Fill in the blank.) A rectangular region is the union of a rectangle and _____.

²In Grade 8, a *region* refers to a *polygonal region* (triangle, quadrilateral, pentagon, and hexagon), a *circular region*, or regions that can be decomposed into such regions.

Discussion

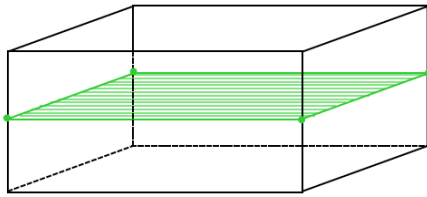

Figure 2

Example of a cross-section of a prism, where the intersection of a plane with the solid is parallel to the base.

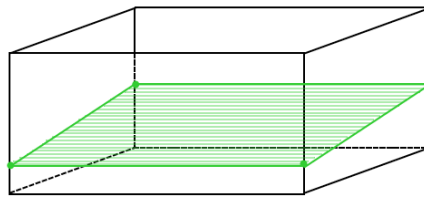
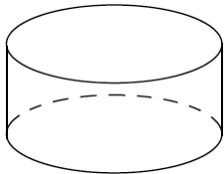
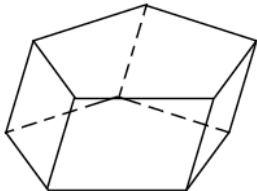
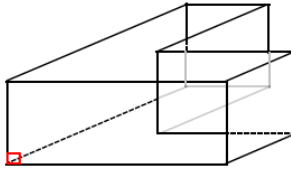
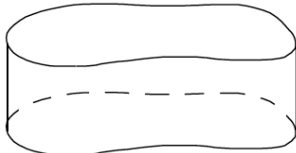

Figure 3

A general intersection of a plane with a prism, which is sometimes referred to as a slice.

Exercise

Sketch the cross-section for the following figures:

<p>a.</p> 	<p>b.</p> 	<p>c.</p> 	<p>d.</p> 
Empty space for sketching	Empty space for sketching	Empty space for sketching	Empty space for sketching

Extension

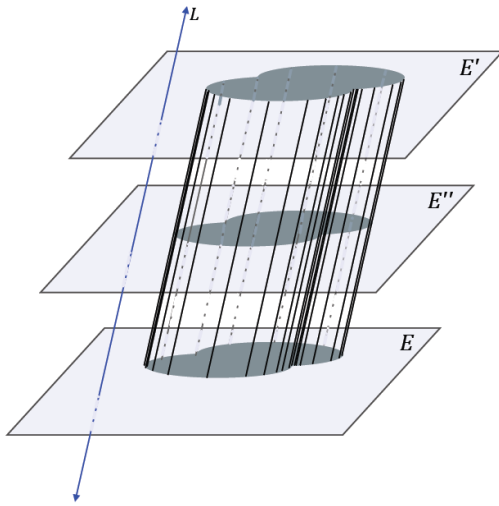

Figure 4

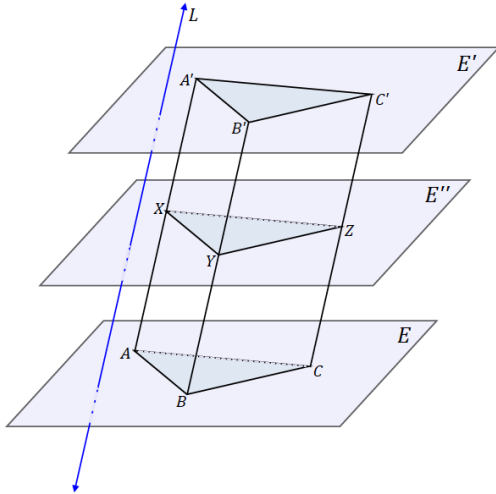

Figure 5

Lesson Summary

RIGHT RECTANGULAR PRISM: Let E and E' be two parallel planes. Let B be a rectangular region in the plane E . At each point P of B , consider $\overline{PP'}$ perpendicular to E , joining P to a point P' of the plane E' . The union of all these segments is called a *right rectangular prism*.

LATERAL EDGE AND FACE OF A PRISM: Suppose the base B of a prism is a polygonal region, and P_i is a vertex of B . Let P'_i be the corresponding point in B' such that $\overline{P_iP'_i}$ is parallel to the line L defining the prism. $\overline{P_iP'_i}$ is called a *lateral edge of the prism*. If $\overline{P_iP_{i+1}}$ is a base edge of the base B (a side of B), and F is the union of all segments PP' parallel to L for which P is in $\overline{P_iP_{i+1}}$ and P' is in B' , then F is a *lateral face of the prism*. It can be shown that a lateral face of a prism is always a region enclosed by a parallelogram.

GENERAL CYLINDER: Let E and E' be two parallel planes, let B be a region in the plane E , and let L be a line that intersects E and E' but not B . At each point P of B , consider $\overline{PP'}$ parallel to L , joining P to a point P' of the plane E' . The union of all these segments is called a *general cylinder with base B* .

Problem Set

1. Complete each statement below by filling in the missing term(s).

- a. The following prism is called a(n) _____ prism.
- b. If $\overline{AA'}$ were perpendicular to the plane of the base, then the prism would be called a(n) _____ prism.
- c. The regions $ABCD$ and $A'B'C'D'$ are called the _____ of the prism.
- d. $\overline{AA'}$ is called a(n) _____.
- e. Parallelogram region $BB'C'C$ is one of four _____.

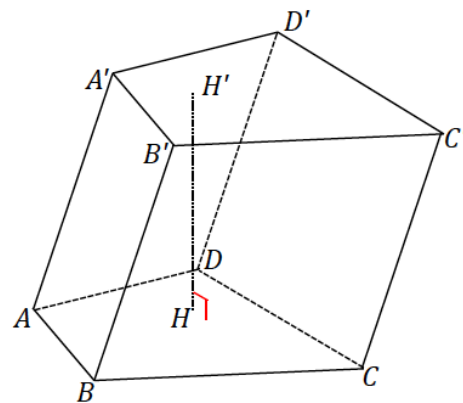

2. The following right prism has trapezoidal base regions; it is a right trapezoidal prism. The lengths of the parallel edges of the base are 5 and 8, and the nonparallel edges are 4 and 6; the height of the trapezoid is 3.7. The lateral edge length DH is 10. Find the surface area of the prism.

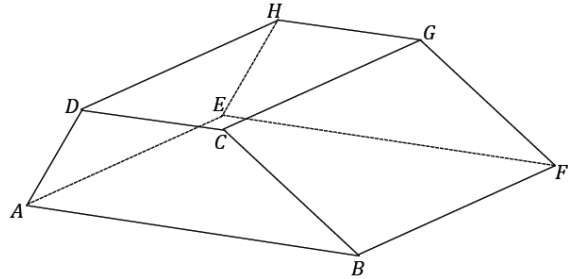

3. The base of the following right cylinder has a circumference of 5π and a lateral edge of 8. What is the radius of the base? What is the lateral area of the right cylinder?

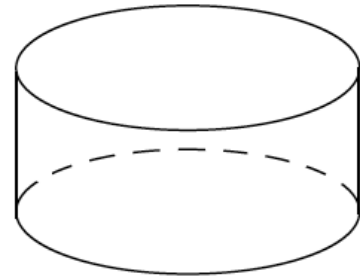

4. The following right general cylinder has a lateral edge of length 8, and the perimeter of its base is 27. What is the lateral area of the right general cylinder?

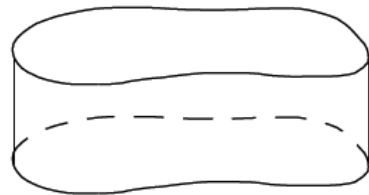

5. A right prism has base area 5 and volume 30. Find the prism's height, h .
6. Sketch the figures formed if the rectangular regions are rotated around the provided axis.

a.



b.

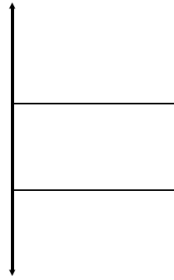

7. A cross-section is taken parallel to the bases of a general cylinder and has an area of 18. If the height of the cylinder is h , what is the volume of the cylinder? Explain your reasoning.
8. A general cylinder has a volume of 144. What is one possible set of dimensions of the base and height of the cylinder if all cross-sections parallel to its bases are...
- Rectangles?
 - Right triangles?
 - Circles?
9. A general hexagonal prism is given. If P is a plane that is parallel to the planes containing the base faces of the prism, how does P meet the prism?
10. Two right prisms have similar bases. The first prism has height 5 and volume 100. A side on the base of the first prism has length 2, and the corresponding side on the base of the second prism has length 3. If the height of the second prism is 6, what is its volume?
11. A tank is the shape of a right rectangular prism with base $2\text{ ft.} \times 2\text{ ft.}$ and height 8 ft. The tank is filled with water to a depth of 6 ft. A person of height 6 ft. jumps in and stands on the bottom. About how many inches will the water be over the person's head? Make reasonable assumptions.

